

APOLLO

Cable and hose reels

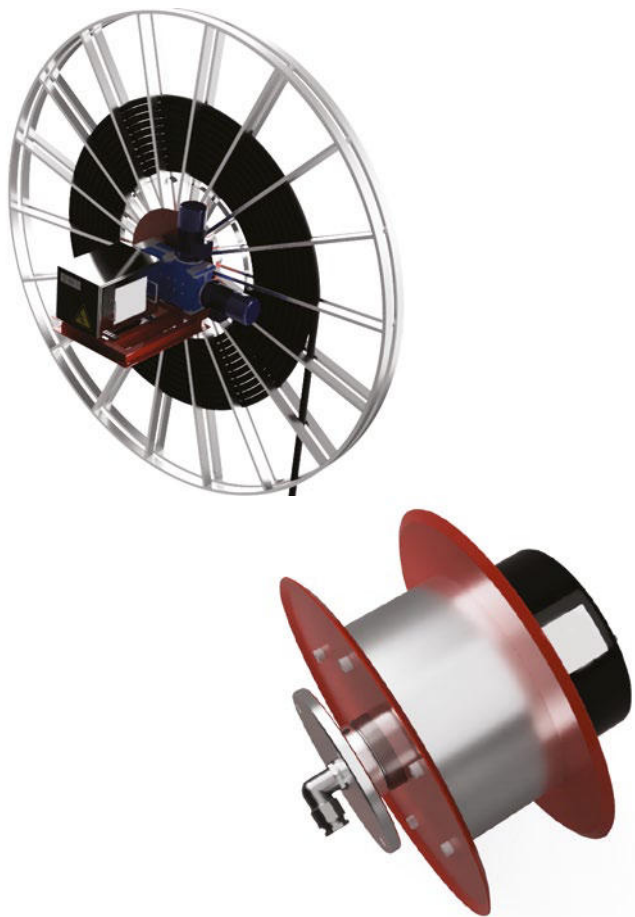

Motor and spring driven cable reels and hose reels, designed to supply control current, data and electric or fluidic power (compressed air, gases, hydraulic oils) to mobile units. Reliability and sturdiness make them particularly suitable for harsh environments, improving work performance and safety in workshops, maintenance services, construction sites, garages, applications in the railway, port and airport sectors etc.

FEATURES

- Motor cable and hose reels, powered by a three-phase torque electric motor.
- Spring cable and hose reels operated by Archimedes spiral springs, offering a variety of performances for effective and economic solutions.
- Equipped with an electric slip ring collector designed to transfer current from a fixed point to rotating parts, transmitting power and both analogue and digital control signals. The slip ring collector, positioned outside the drum, has up to 42 bronze alloy power rings, brass auxiliary rings, gold or silver plated signal rings and patented metal brushes.
- High quality materials and components guarantee reliability, durability and low maintenance. The galvanic treatments on components ensure resistance to corrosion.
- Equipped with sliding contacts to ensure low friction and overheating values at the contact point and at the terminals in case of failure.
- IP protection degree: Apollo motor cable reels are classified up to max. IP65, Apollo spring cables reels are up to max. IP67.
- Extreme temperature resistance: from -15°C to +40°C. (motor cable reel) and from -20°C to +60°C (spring cable reel).

OPTIONS

- Equipped with round or flat power, control or mixed cables, specially designed for reeling applications.
- On request, they can be equipped with limit switches, anti-condensation heaters, sockets or connectors, spring dumpers, two-way cable guides, tiles and other accessories..
- High degree of customization thanks to a fully modular construction system.
- Versions for marine environment made of stainless steel AISI 316L, suitable for low temperatures (down to -40°C) are available.
- Atex versions available.

CERTIFICATIONS

- CE Marking.

Fill in the "request form" for accurate product configuration.

APOLLO MOTOR REELS

Motor cable and hose reels powered by a three-phase torque electric motor, particularly suitable for use on overhead travelling cranes and material handling machines for steel mills, lifting, construction and handling plants.

Designed for transferring current to mobile units by means of low voltage cables.

They can be equipped with data transmission or power transmission slip ring collectors, depending on size and application. Compact, simple, robust and reliable thanks to the high quality materials and components, which guarantee durability over time and reduced maintenance requirements. Stainless steel slip ring collector carter, blue or black painted die cast aluminum motor housing, red painted aluminum or cast iron gearbox support. Spool with diameter up to 800 mm made of red painted shaped sheet metal; spool with diameter over 800 mm made of hot painted drawn sheet metal. Stainless steel AISI 304 drum.



CERTIFICATIONS

Conformity to Community Directives	2006/42/CE Machinery Directive
	EN 60204-1 Safety of machinery - Electrical equipment of machines
Conformity to CE Standards	EN 60309-1-2 Plugs, socket-outlets and couplers for industrial purposes
	EN 60947-1-1 Low-voltage switchgear and controlgear
Markings and homologations	CE

GENERAL TECHNICAL SPECIFICATIONS

Ambient temperature	Operational -15°C/+40°C
IP protection degree	IP 65
Max. working altitude	1500 m above sea level
Rated operational current	Up to 400 A
Rated operational voltage	690 Vac

TECHNICAL SPECIFICATIONS OF THE MOTOR

Type	Standard 3 phase torque electric motor	3 phase high torque electric motor
Rated operational voltage		230/400 Vac
Torque	2 to 8.5 Nm self-ventilated (optional servo-ventilated)	10,12, 17, 22, 35 Nm servo-ventilated
Frequency		50 Hz
IP protection degree	IP 55	IP 65
Insulation category		Class H

OPTIONS

Special 3 phase electric motor	Special voltages up to 660 Vac
	Tropicalization T -15°C +40°C / HR 90%
	Servo-ventilation for 2, 3,4.5, 6 Nm
Limit switch	4 adjustable positions
Heating	From 100 W to 200 W, pre-wired

STANDARD CABLES

Collector rings	Type	Weight (kg/m)	Diameter (mm)
4 x 40 A	4G6	0.39	16.9
4 x 60 A	4G10	0.61	18.9
4 x 80 A	4G16	0.94	22.5
4 x 100 A	3 x 25 + 3G6	1.24	25.4
4 x 150 A	3 x 35 + 3G10	1.64	28.2
4 x 200 A	3 x 50 + 3G16	2.10	32
4 x 250 A	3 x 70 + 3G25	2.70	36
5 x 40 A	5G6	0.49	18.4
5 x 60 A	5G10	0.72	21.4
5 x 80 A	5G16	1.12	24.7
5 x 100 A	5G25	1.57	30.7
12 x 20 A	12 x 2.5	0.7	21
18 x 20 A	18 x 1.5	0.43	17.4
18 x 20 A	18 x 2.5	0.76	21.8
24 x 20 A	24 x 1.5	0.7	20.3
24 x 20 A	24 x 2.5	1.07	25.8
36 x 20 A	36 x 1.5	0.92	22.4
36 x 20 A	36 x 2.5	1.45	28.8
42 x 20 A	42 x 2.5	1.52	30.9

OVERALL DIMENSIONS (mm)

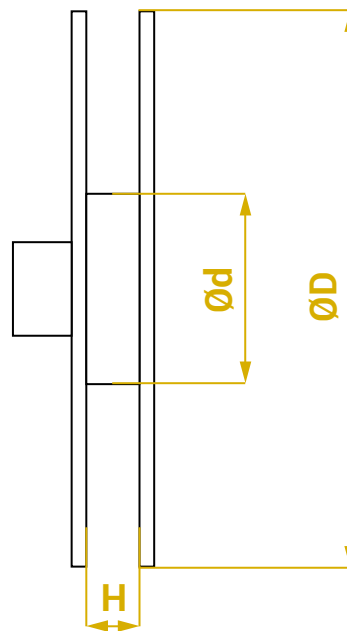
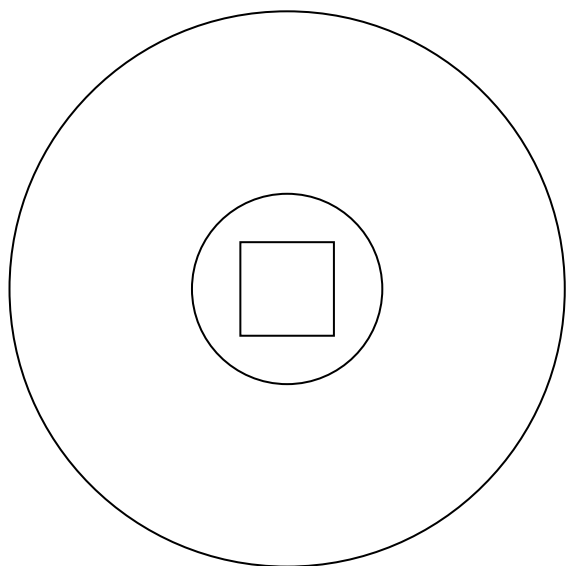

ACCESSORIES

Code	Description
AGCB	Bidirectional cable guide
AMDC	Cable feed point
AQG	Roller cable reel
ACM	Cable socks
AMA	Spring damper

STANDARD HORIZONTAL MOTOR CABLE REELS

Cable seat width: 23 mm

Code	Run (m)	Cable	Type	ØD External diameter (mm)	Ød Internal diameter (mm)	H Cable seat width (mm)	Meters of wrapped cable
APMA090M0212601H4080	20	4G16	PUR	1200	600	23	25
APMA090M0212601H4080	30	4G16	PUR	1200	600	23	35
APMA090M0214601H4080	40	4G16	PUR	1400	600	23	45
APMA090M0214601H4080	50	4G16	PUR	1400	600	23	55
APMA090M0316601H4080	60	4G16	PUR	1600	600	23	65
APMA090M0316601H4080	70	4G16	PUR	1600	600	23	75
APMA090M0318601H4080	80	4G16	PUR	1800	600	23	85
APMA090M0318601H4080	90	4G16	PUR	1800	600	23	95
APMA090M0320801H4080	100	4G16	PUR	2000	800	23	105
APMA090M0320801H4080	110	4G16	PUR	2000	800	23	115
APMA090M04522801H4080	120	4G16	PUR	2000	800	23	125

Cable seat width: 35 mm

Code	Run (m)	Cable	Type	ØD External diameter (mm)	Ød Internal diameter (mm)	H Cable seat width (mm)	Meters of wrapped cable
APMA112M04512601W4150	20	4G35	PUR	1200	600	35	25
APMA112M04514601W4150	30	4G35	PUR	1400	600	35	35
APMA112M04514601W4150	40	4G35	PUR	1600	600	35	45
APMA112M0616601W4150	50	4G35	PUR	1600	600	35	55
APMA112M0618601W4150	60	4G35	PUR	1800	600	35	65
APMA112M0618601W4150	70	4G35	PUR	1800	600	35	75
APMA112M0620801W4150	80	4G35	PUR	2000	800	35	85
APMA112M0622801W4150	90	4G35	PUR	2200	800	35	95
APMA112M0622801W4150	100	4G35	PUR	2200	800	35	105
APMA112M07524801W4150	110	4G35	PUR	2400	800	35	115
APMA112M07524801W4150	120	4G35	PUR	2400	1000	35	125

Cable seat width: 40 mm

Code	Run (m)	Cable	Type	ØD External diameter (mm)	Ød Internal diameter (mm)	H Cable seat width (mm)	Meters of wrapped cable
APMA140M04514602W4200	20	4G35	PUR	1400	600	40	25
APMA140M0616602W4200	30	4G35	PUR	1600	600	40	35
APMA140M0618602W4200	40	4G35	PUR	1800	600	40	45
APMA140M0718602W4200	50	4G35	PUR	1800	600	40	55
APMA140M0720602W4200	60	4G35	PUR	2000	800	40	65
APMA140M0722802W4200	70	4G35	PUR	2200	600	40	75
APMA140M0722802W4200	80	4G35	PUR	2200	800	40	85
APMA140M08524802W4200	90	4G35	PUR	2400	800	40	95
APMA140M08524802W4200	100	4G35	PUR	2400	800	40	105
APMA140M08526802W4200	110	4G35	PUR	2600	800	40	115
APMA140M08526802W4200	120	4G35	PUR	2600	1000	40	125

APOLLO SPRING REELS

Spring cable and hose reels operated with Archimedes spiral springs for effective and economic solutions, particularly suitable for use even in small spaces for lifting, water treatment plants and process machines. Designed for the transmission of electric power to mobile units.

They can be equipped with data transmission or power transmission slip ring collectors, depending on size and application. Compact, simple, robust and reliable thanks to the high quality materials and components, which guarantee durability over time and reduced maintenance requirements. Carter made of stainless steel, spiral springs made of high quality spring steel. Galvanized or stainless steel AISI 316L (marine version) drum.



CERTIFICATIONS

Conformity to Community Directives	2006/42/CE Machinery Directive
	EN 60204-1 Safety of machinery - Electrical equipment of machines
Conformity to CE Standards	EN 60309-1-2 Plugs, socket-outlets and couplers for industrial purposes
	60947-1-1 Low-voltage switchgear and controlgear
Markings and homologations	CE

GENERAL TECHNICAL SPECIFICATIONS

Ambient temperature	Operational -20°C/+60°C (on request -40°C/+60°C)
IP protection degree	IP65 / IP67
Rated operational current	Up to 250 A
Rated operational voltage max.	400 / 1000 Vac

STANDARD CABLE REELS

Collector - rings	Type	Weight (Kg/m)	Diameter (mm)
4 x 20A	4G2.5	0.2	14
4 x 40A	4G4	0.28	15.3
4 x 40A	4G6	0.39	16.9
4 x 60A	4G10	0.61	18.9
4 x 80A	4G16	0.94	22.5
4 x 100A	3 x 25 + 3G6	1.24	25.4
4 x 150A	3 x 35 + 3G10	1.64	28.2
4 x 200A	3 x 50 + 3G16	2.10	32
4 x 250	3 x 70 + 3G25	2.70	36
5 x 25A	5G2.5	0.24	15.1
5 x 40A	5G4	0.34	16.6
5 x 40A	5G6	0.49	18.4
5 x 60A	5G10	0.72	21.4
5 x 80A	5G16	1.12	24.7
5 x 100A	5G25	1.57	30.7
7 x 20A	7 x 1.5	0.21	13
7 x 20A	7 x 2.5	0.35	16
12 x 20A	12 x 1.5	0.41	17
12 x 20A	12 x 2.5	0.7	21
18 x 20A	18 x 1.5	0.43	17.4
18 x 20A	18 x 2.5	0.76	21.8
24 x 20A	24 x 1.5	0.7	20.3
24 x 20A	24 x 2.5	1.07	25.8
36 x 20A	36 x 1.5	0.92	22.4
36 x 20A	36 x 2.5	1.45	28.8
42 x 20A	42 x 2.5	1.52	30.9

ACCESSORIES

Code	Description
AQG	Roller cable reel
AS230	Cable guide
AF150	Support bracket
AF151	Swiveling support bracket
ACM	Cable socks

APOLLO SPRING REELS - STANDARD SERIES

APOLLO S1



Overall dimensions (mm)

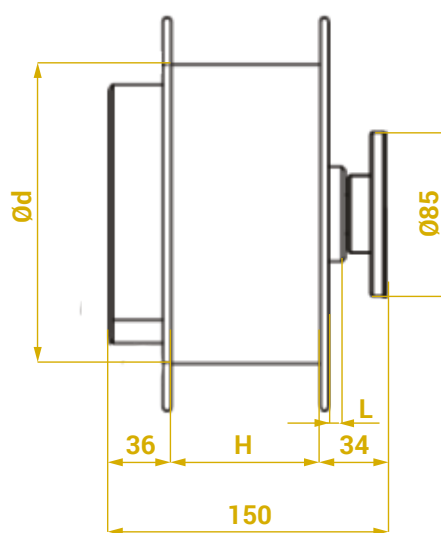
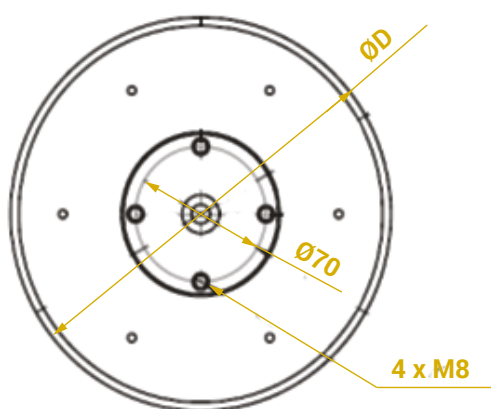

Horizontal cable winding

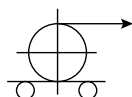

Spring type: height=18 mm, depth=0.6 mm, external \varnothing =135 mm, internal \varnothing =22 mm, length=9m.

Code	Cable length (m)	Cable type	No. of springs	ØD External diameter (mm)	Ød Internal diameter (mm)	H Cable seat width (mm)	Slip ring collector		
							L Slip ring cover dimensions (mm)	No. of rings	Rated operational current
APS012115081A1L4A10	5 - 10	4G1	1	210	155	80	5	4	10 A
APS012115081A1L4A16	5 - 10	4G1.5	1	210	155	80	5	4	16 A
APS012115081A1L7A10	5 - 10	7G1	1	210	155	80	5	7	10 A

Vertical cable winding

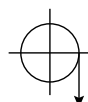

Spring type: height=18 mm, depth=0.6 mm, external \varnothing =135 mm, internal \varnothing =22 mm, length=9m.

Code	Cable length (m)	Cable type	No. of springs	ØD External diameter (mm)	Ød Internal diameter (mm)	H Cable seat width (mm)	Slip ring collector		
							L Slip ring cover dimensions (mm)	No. of rings	Rated operational current
APS012115082A2L4A10	5 - 10	4G1	2	210	155	80	90	4	10 A
APS012115082A2L4A16	5 - 10	4G1.5	2	210	155	80	90	4	16 A
APS012115082A2L7A10	5 - 10	7G1	2	210	155	80	90	7	10 A

APOLLO S2



Overall dimensions (mm)

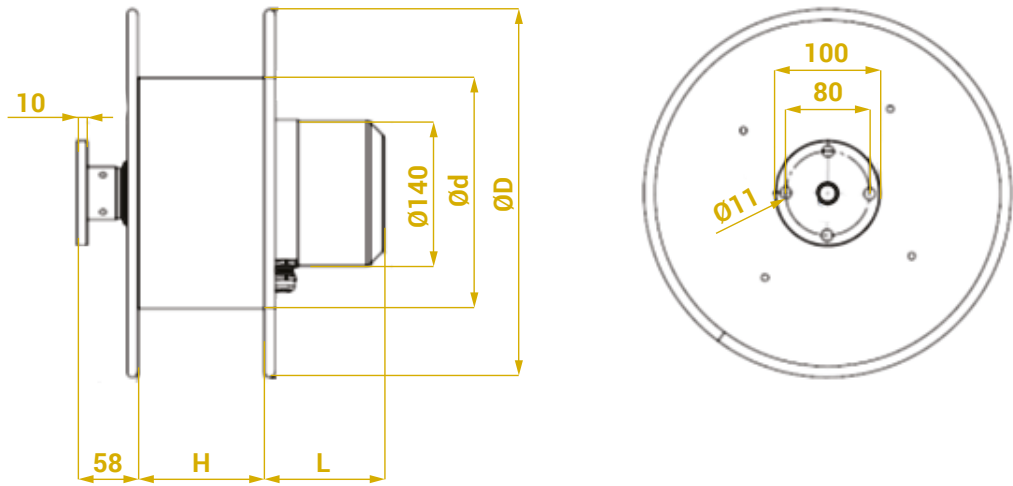

Horizontal cable winding

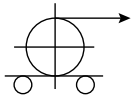

Spring type: height=40 mm, depth=0.6 mm, external Ø=190 mm, internal Ø=25 mm, length=15m.

Code	Cable length (m)	Cable type	No. of springs	ØD External diameter (mm)	Ød Internal diameter (mm)	H Cable seat width (mm)	Slip ring collector		
							L Slip ring cover dimensions (mm)	No. of rings	Rated operational current
APS023522101B1L4A20	10 - 15	4G2.5	1	350	220	120	5	4	20 A
APS023522102B1L4A20	10 - 15	5G2.5	2	350	220	120	5	4	20 A
APS023522102B1L5A20	15 - 20	5G2.5	2	350	220	120	5	5	20 A
APS023522101B1L4A30	10 - 15	4G4	1	350	220	120	5	4	30 A
APS024022102B1L4A30	15 - 20	4G4	2	400	220	120	5	4	30 A
APS023522102B1L7A20	10 - 15	7G2.5	2	350	220	120	5	7	20 A
APS023522102B2L12A10	10 - 15	12G1	2	350	220	120	90	12	10 A
APS024022102B2L12A10	15 - 20	12G1	2	400	220	120	90	12	10 A
APS023522102B2L12A16	10 - 15	12G1.5	2	350	220	120	90	12	16 A
APS024022102B2L12A16	10 - 15	12G1.5	2	400	220	120	90	12	16 A

Vertical cable winding

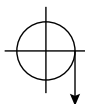

Spring type: height=40 mm, depth=0.6 mm, external $\varnothing=190$ mm, internal $\varnothing=25$ mm, length=15m.

Code	Cable length (m)	Cable type	No. of springs	$\varnothing D$ External diameter (mm)	$\varnothing d$ Internal diameter (mm)	H Cable seat width (mm)	Slip ring collector		
							L Slip ring cover dimensions (mm)	No. of rings	Rated operational current
APS023522122B1L4A20	10 - 15	4G2.5	2	350	220	120	5	4	20 A
APS023522122B1L5A20	10 - 15	5G2.5	2	350	220	120	5	5	20 A
APS024022122B1L5A20	15 - 20	5G2.5	2	400	220	120	5	5	20 A
APS023522122B1L4A30	10 - 15	4G4	2	350	220	120	5	4	30 A
APS024022122B1L4A30	15 - 20	4G4	2	400	220	120	5	4	30 A
APS023522122B1L7A20	10 - 15	7G2.5	2	350	220	120	5	7	20 A
APS023522122B2L12A10	10 - 15	12G1	2	350	220	120	90	12	10 A
APS024022122B2L12A10	15 - 20	12G1	2	400	220	120	90	12	10 A
APS023522122B2L12A16	10 - 15	12G1.5	2	350	220	120	90	12	16 A
APS024022122B2L12A16	10 - 15	12G1.5	2	400	220	120	90	12	16 A

APOLLO S3



Overall dimensions (mm)

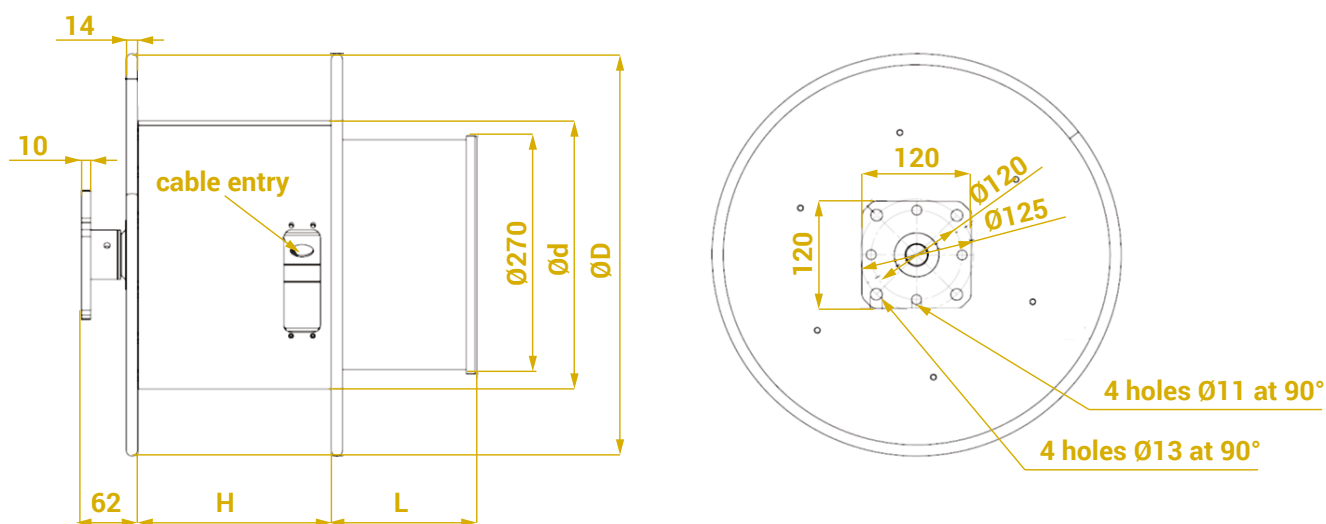

Horizontal cable winding

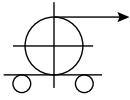

Spring type: height=40 mm, depth=1.1 mm, external Ø=265 mm, internal Ø=45 mm, length=18m.

Code	Cable length (m)	Cable type	No. of springs	ØD External diameter (mm)	Ød Internal diameter (mm)	H Cable seat width (mm)	Slip ring collector		
							L Slip ring cover dimensions (mm)	No. of rings	Rated operational current
APS034530211H1L5A30	10 - 30	5G4	1	450	300	210	5	5	30 A
APS034530211H1L4A50	10 - 30	4G6	1	450	300	210	5	4	50 A
APS034530212H1L5A50	10 - 30	5G6	2	450	300	210	5	5	50 A
APS035730212H2L4A80	10 - 30	4G10	2	570	300	210	90	4	80 A
APS035730212H2L4A100	10 - 30	4G16	2	570	300	210	90	4	100 A
APS035730212H3L18A16	10 - 30	18G1.5	2	570	300	210	160	18	16 A
APS034530212H3L18A20	10 - 30	18G2.5	2	450	300	210	160	18	20 A
APS035730212H3L24A16	10 - 30	24G1.5	2	570	300	210	160	24	16 A
APS034530212H3L24A20	10 - 30	24G2.5	2	450	300	210	160	24	20 A

Vertical cable winding

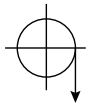

Spring type: height=40 mm, depth=1.35 mm, external Ø=265 mm, internal Ø=45 mm, length=15m.

Code	Cable length (m)	Cable type	No. of springs	ØD External diameter (mm)	Ød Internal diameter (mm)	H Cable seat width (mm)	Slip ring collector		
							L Slip ring cover dimensions (mm)	No. of rings	Rated operational current
APS034530211J1L5A30	10 - 20	5G4	1	450	300	210	5	5	30 A
APS034530211J1L4A50	10 - 20	4G6	1	450	300	210	5	4	50 A
APS034530211J1L5A50	10 - 20	5G6	1	450	300	210	5	5	50 A
APS034530212J2L4A80	10 - 20	4G10	2	450	300	210	90	4	80 A
APS034530212J2L4A100	10 - 20	4G16	2	450	300	210	90	4	100 A
APS035730212J3L18A16	10 - 20	18G1.5	2	570	300	210	160	18	16 A
APS034530212J3L18A20	10 - 20	18G2.5	2	450	300	210	160	18	20 A
APS035730212J3L24A16	10 - 20	24G1.5	2	570	300	210	160	24	16 A
APS034530212J3L24A20	10 - 20	24G2.5	2	450	300	210	160	24	20 A

APOLLO S4



Overall dimensions (mm)

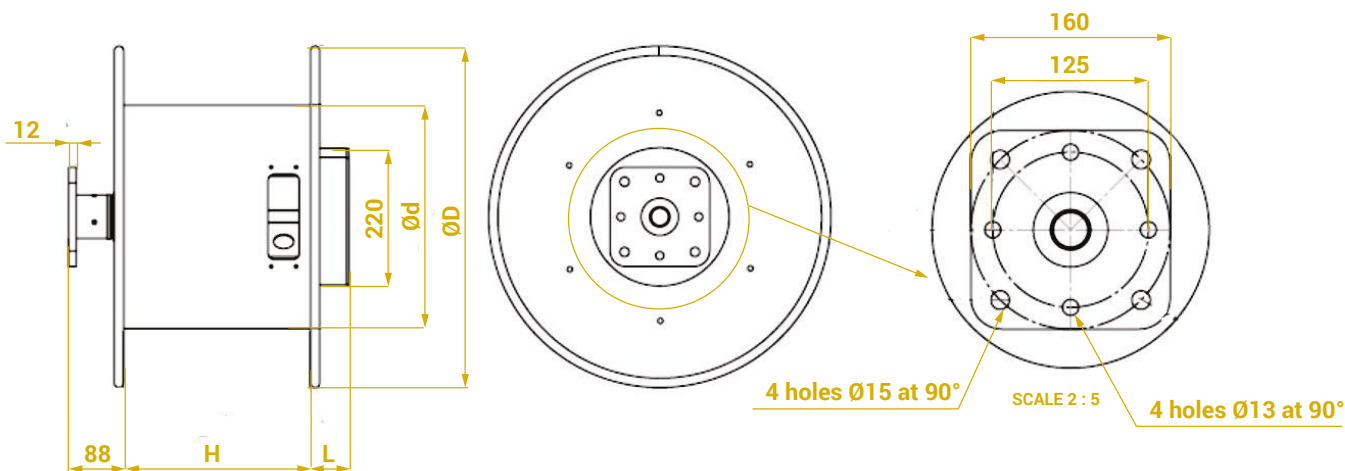

Horizontal cable winding

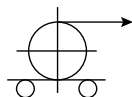

Spring type: height=40 mm, depth=1.35 mm, external \varnothing =265 mm, internal \varnothing =45 mm, length=15m.

Code	Cable length (m)	Cable type	No. of springs	\varnothing D External diameter (mm)	\varnothing d Internal diameter (mm)	H Cable seat width (mm)	Slip ring collector		
							L Slip ring cover dimensions (mm)	No. of rings	Rated operational current max
APS045736302J2L4A100	10 - 20	4G25	2	570	360	300	90	4	100 A
APS045736302J2L4A150	10 - 20	4G35	2	570	360	300	90	4	150 A

Vertical cable winding

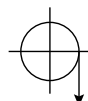

Spring type: height=40 mm, depth=1.35 mm, external \varnothing =265 mm, internal \varnothing =45 mm, length=15m.

Code	Cable length (m)	Cable type	No. of springs	\varnothing D External diameter (mm)	\varnothing d Internal diameter (mm)	H Cable seat width (mm)	Slip ring collector		
							L Slip ring cover dimensions (mm)	No. of rings	Rated operational current max
APS045736302J2L4A100	10 - 20	4G25	2	570	360	300	90	4	100 A
APS045736303J2L4A150	10 - 20	4G35	3	570	360	300	90	4	150 A

APOLLO - REQUEST FORM FOR MOTOR CABLE AND HOSE REELS

Winding

Single turn Multiple turns

Unwinding direction (view from slip ring side)

CW CCW

Installation

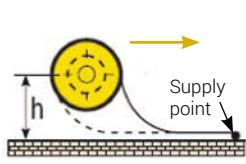

Reel on a mobile device

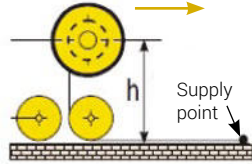

Reel on a mobile device with cable guide

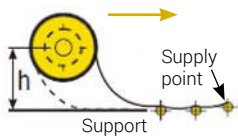

Fixed reel with mobile supply point

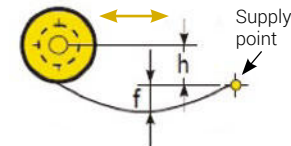

Fixed reel with hanging mobile supply point
f (Max)= _____ m

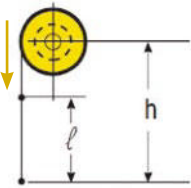

From top to bottom

Fixed reel Mobile reel

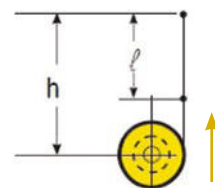

From bottom to top

Fixed reel Mobile reel

Specifications of the application

Motor _____ V _____ Hz

Work run (m) _____

IP protection degree _____

Speed (m/min) _____

Height from ground to reel centre (h)* (m) _____

Work environment _____

Time of acceleration (s) _____

Operating voltage (V) _____

ATEX enclosure _____

* See drawings above.

Cable

Supplied with cable Yes No

If Yes, fill in the cable specifications below

Cable type _____

Cable section (mm²) _____

Cable diameter (mm) _____

Cable weight (kg/m) _____

Number of always winded turns _____

Always winded cable (m) _____

Always unwinded cable (m) _____

Total cable on the reel (m) _____

Fixed point cable (m) _____

Insulation (V) _____

Slip ring collector

Fill in the slip ring collector specifications below

Number of rings _____ Ampere (A) _____

Number of rings _____ Ampere (A) _____

Number of rings _____ Ampere (A) _____

Number of rings _____ Ampere (A) _____

Remarks _____

Accessories

Bidirectional cable guide

Cable feed point

Roller cable reel

Cable socks

Spring damper

Remarks

APOLLO - REQUEST FORM FOR SPRING CABLE AND HOSE REELS

Winding

Single turn Multiple turns

Unwinding direction (view from slip ring side)

CW CCW

Installation

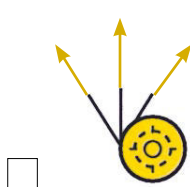
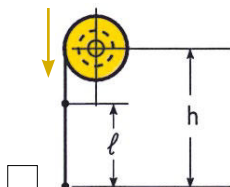
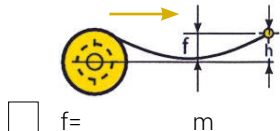
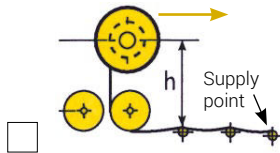
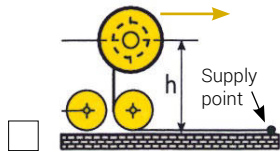
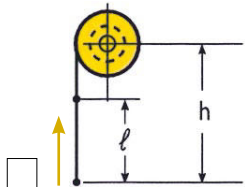
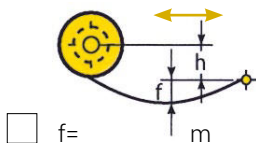
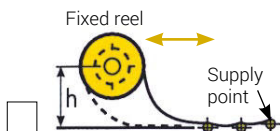
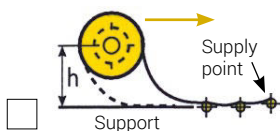
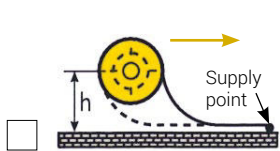

Accessories

- Roller cable reel
- Cable guide
- Support bracket
- Swiveling support bracket
- Cable socks

Remarks

Specifications of the application

Application Horizontal Vertical

Work run (m) _____

IP protection degree _____

Speed (m/min) _____

Height from ground to reel centre (h)* (m) _____

Work environment _____

Time of acceleration (s) _____

Operating voltage (V) _____

Temperature (°C) _____

ATEX enclosure _____

* See drawings to the left.

Cable

Fill in the cable specifications below

Cable type _____

Cable section (mm²) _____

Cable diameter (mm) _____

Cable weight (kg/m) _____

Always wound cable (m) _____

Always unwound cable (m) _____

Total cable on the reel (m) _____

Fixed point cable (m) _____

Slip ring collector

Supplied with slip ring collector Yes No

If Yes, fill in the slip ring collector specifications below

Number of rings _____ Ampere (A) _____

Number of rings _____ Ampere (A) _____

Number of rings _____ Ampere (A) _____

Number of rings _____ Ampere (A) _____

Number of rings _____ Ampere (A) _____

Number of rings _____ Ampere (A) _____

